

THIS DRAWING IS UNPUBLISHED. RELEASED FOR PUBLICATION 2011
 © COPYRIGHT 2011 TE CONNECTIVITY ALL RIGHTS RESERVED.

LOC		DIST		REVISIONS			
P	LTR	DESCRIPTION		DATE	DWN	APVD	
	H	ECR-11-021290		-	PS	RRP	
	J	ECO-16-001320		13JUN2016	AD	SH	
	L	ECO-18-000280		08JAN2018	AD	SH	
	LI	REVISED PER ECN-22-180673		09NOV2022	AB	SZ	

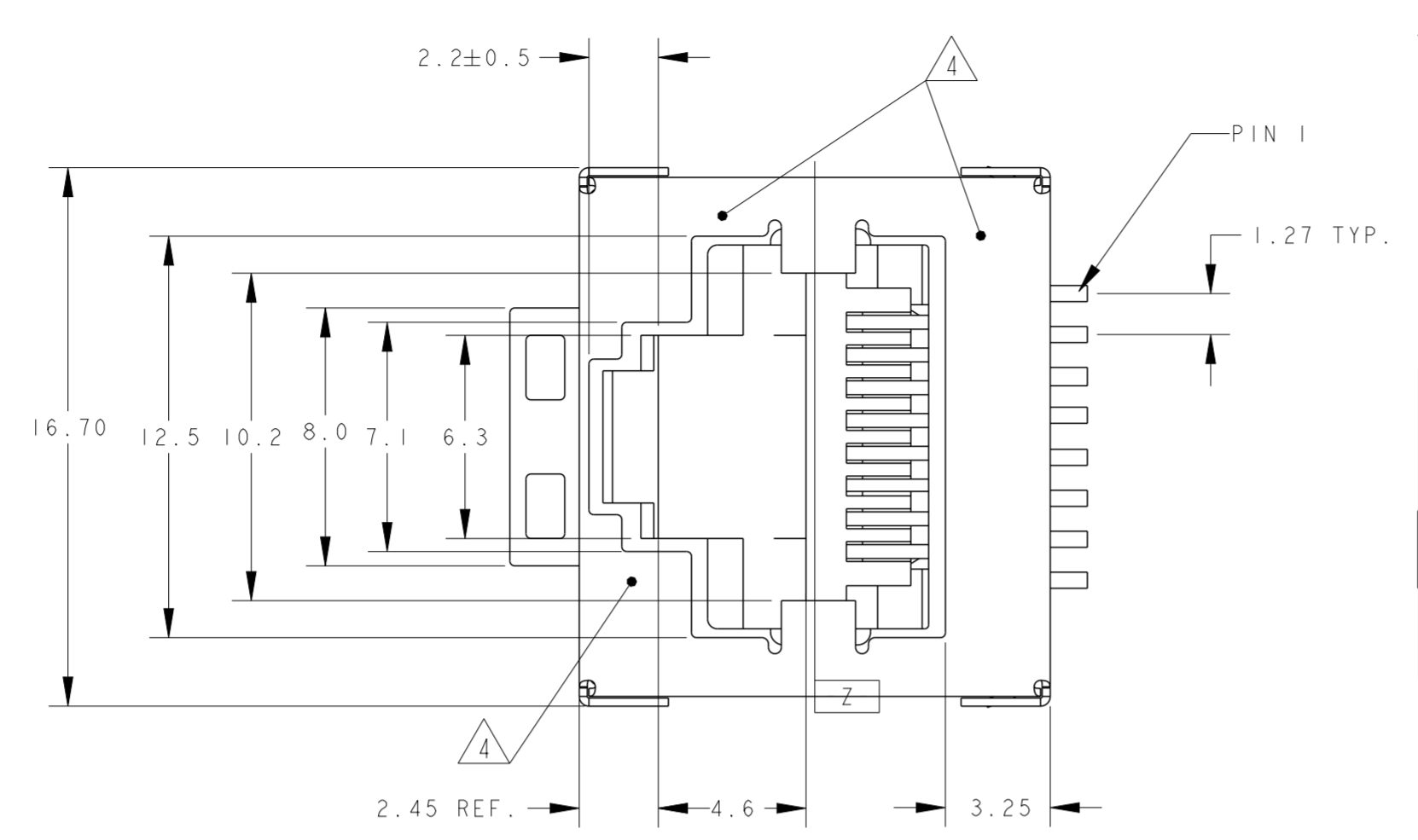

△1705549-3 AS SHOWN

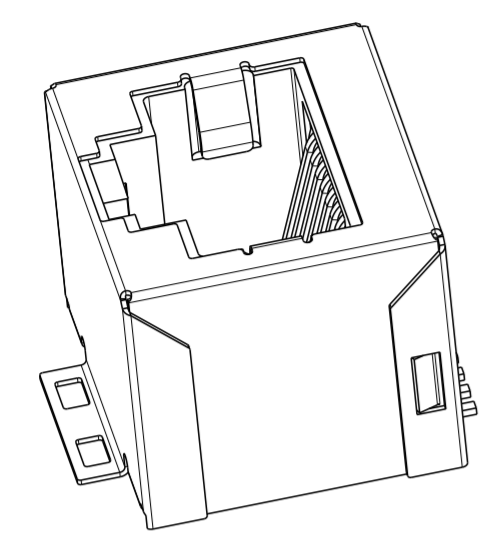
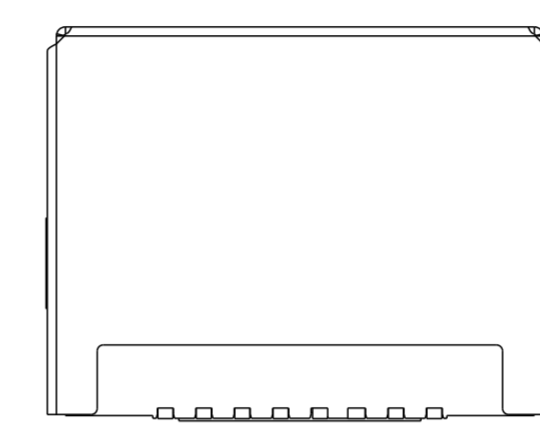

△1705549-3 AS SHOWN

NOTES:

- 1 TOLERANCES UNLESS OTHERWISE SPECIFIED: ±0,15
- 2 CONTACT PLATING:
 OVERALL: Ni 1.27µm MIN. ALL OVER THE CONTACTS
 SOLDER ZONE: Sn 3.5-5.0µm ON THE SOLDER ZONE OF THE CONTACT
 MATING ZONE: PLATING CONFIRMS TO PRODUCT REQUIREMENTS AS PER SPECIFICATION 108-19117
- 3 MATERIAL:
 HOUSING: 30% G.F. PA 4T COLOR YELLOW, UL 94V-0
 CONTACTS: PHOSPHOR BRONZE
 SHIELD: TINPLATED BRASS
- 4 SURFACE CAN BE USED FOR PICKING THE MODULAR JACK WITH TYPE II SMD MACHINE.
- 5 MEASURED AT HEEL OF CONTACTS.
 COPLANARITY AT TIPS MAX. 0,18 mm.
- 6 TAPE AND REEL PACKING AS PER EIA 481-3
- 7 MATERIAL:
 HOUSING: 30% G.F. LCP COLOR BLACK, UL 94V-0
 CONTACTS: PHOSPHOR BRONZE
 SHIELD: TINPLATED BRASS

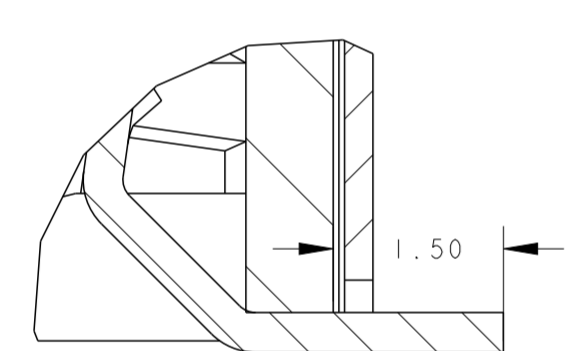

DETAIL Z
SCALE 15:1

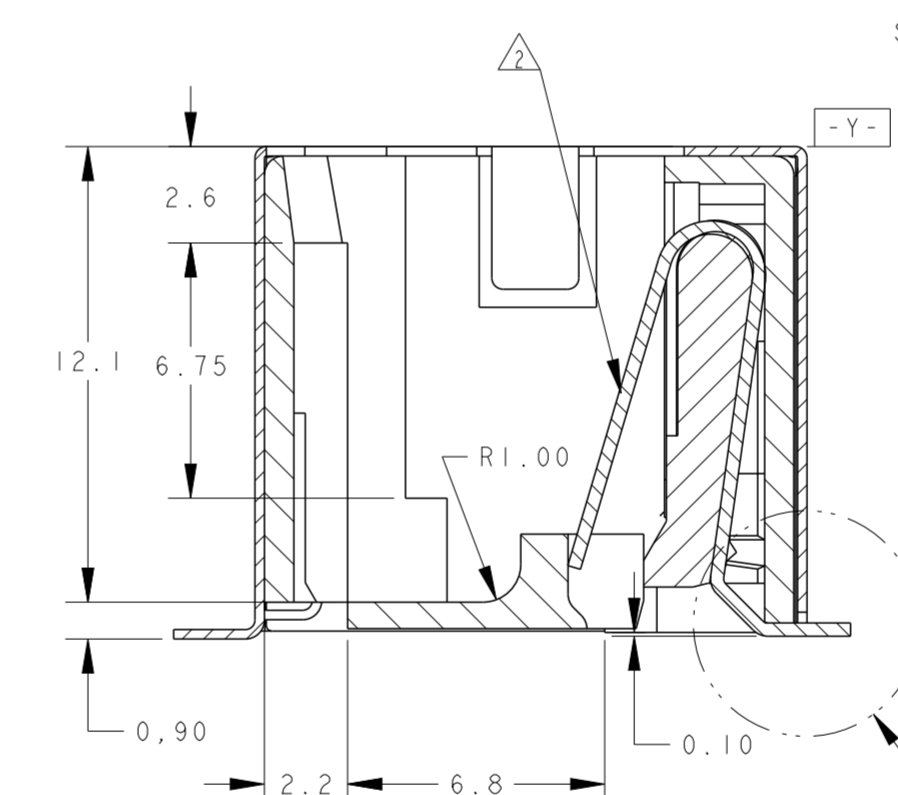
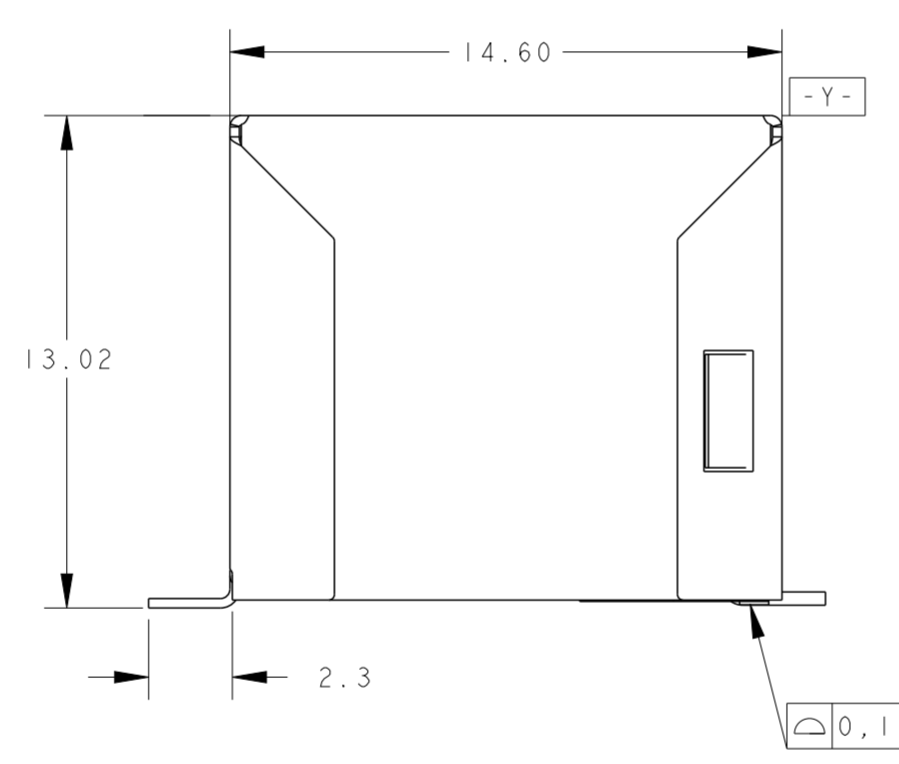

SECTION A-A

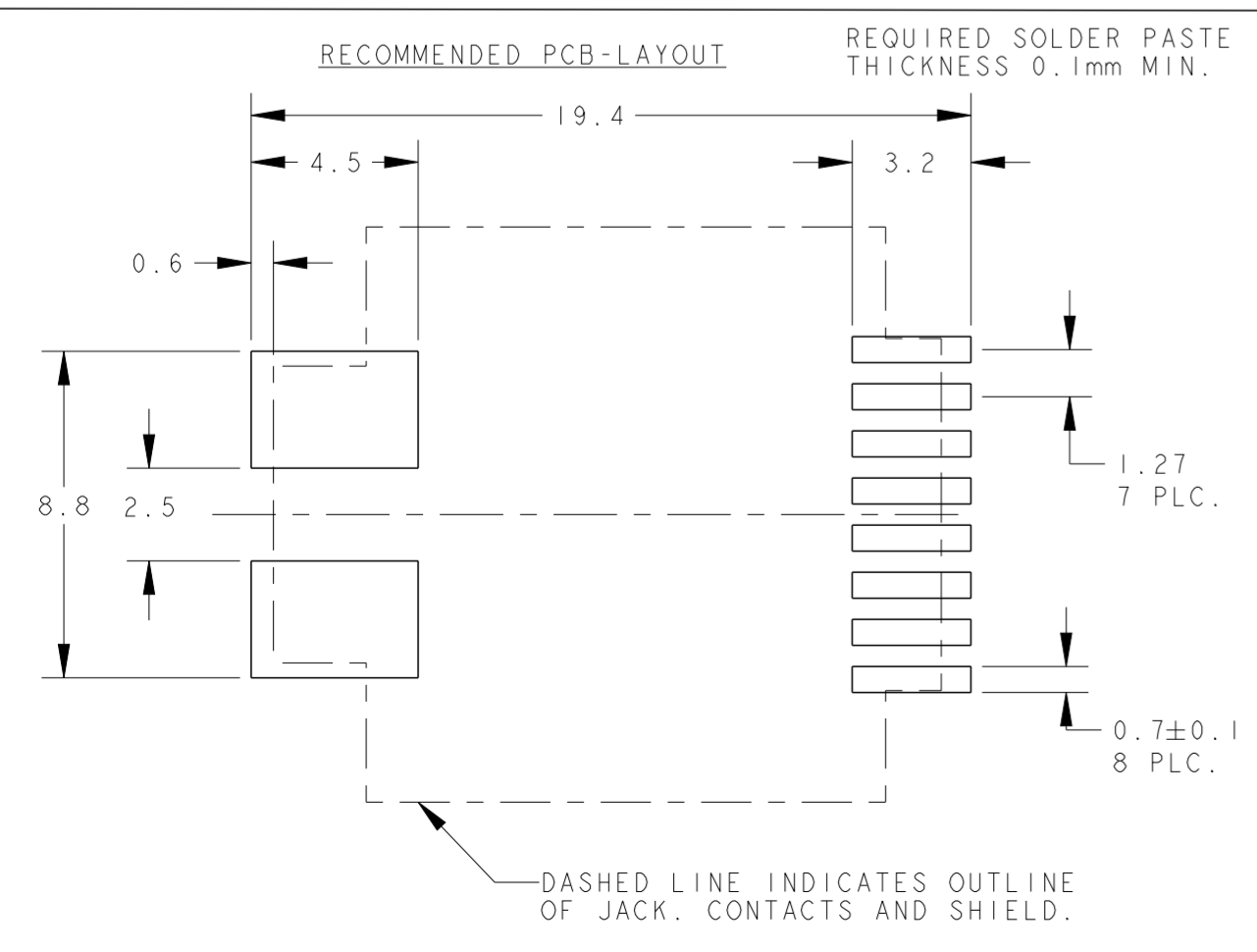
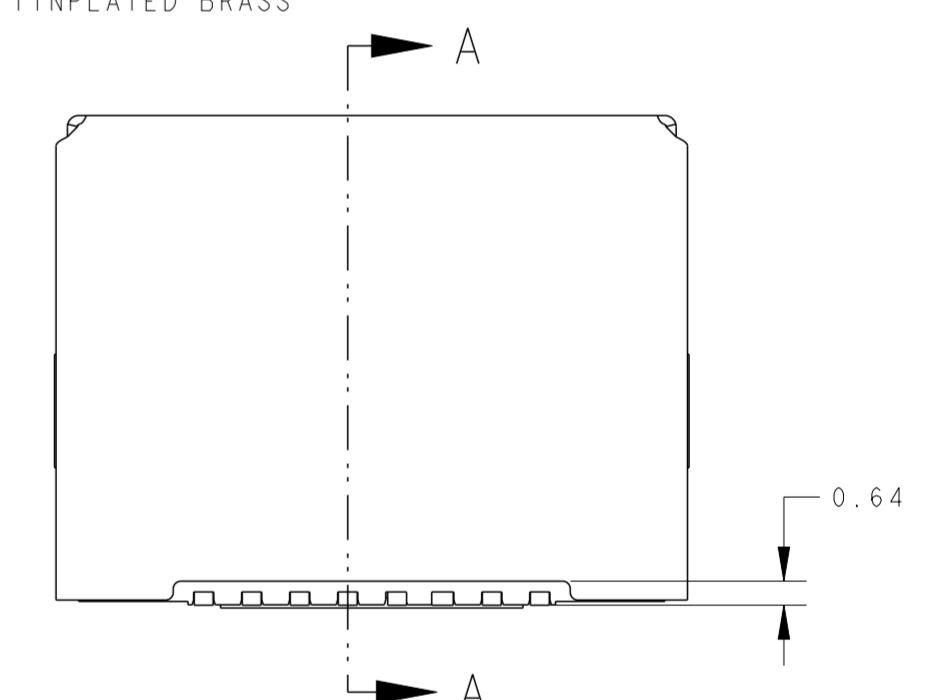

DASHED LINE INDICATES OUTLINE OF JACK. CONTACTS AND SHIELD.

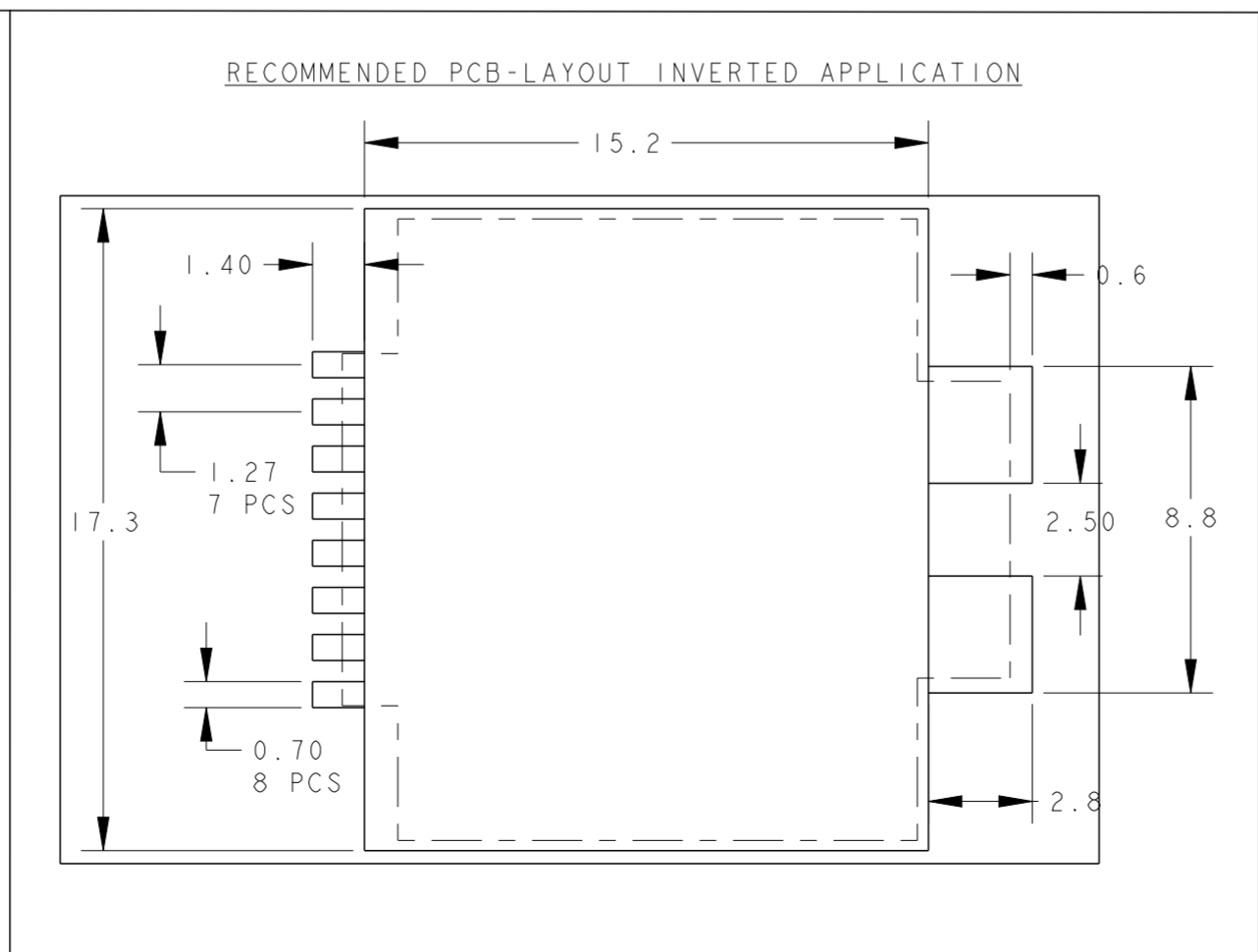

OBSELETE	△7	BLACK	1705549-3	3
OBSELETE	△3	YELLOW	1705549-2	2
	△7	BLACK	1705549-1	1
MATERIAL	COLOUR	PART NUMBER	SL NO.	

1705549-1 AS SHOWN.

THIS DRAWING IS A CONTROLLED DOCUMENT.

DWN: P. WILLEMS, 17 JUN 04
 CHK: P. GROELS, 17 JUN 04
 APVD: P. JAEGER

TE Connectivity
STE

MODULAR JACK SMT, 8 POSITION

SIZE: A2, CAGE CODE: 0779, DRAWING NO: C-1705549, RESTRICTED TO: L1

SCALE: 5:1, SHEET: 1 OF 2, REV: L1

THIS DRAWING IS UNPUBLISHED. RELEASED FOR PUBLICATION 2011
 © COPYRIGHT 2011 TE CONNECTIVITY ALL RIGHTS RESERVED.

LOC	DIST	REVISIONS			
P	LTR	DESCRIPTION	DATE	DWN	APVD
IR	-	SEE SHEET 1	-	-	-

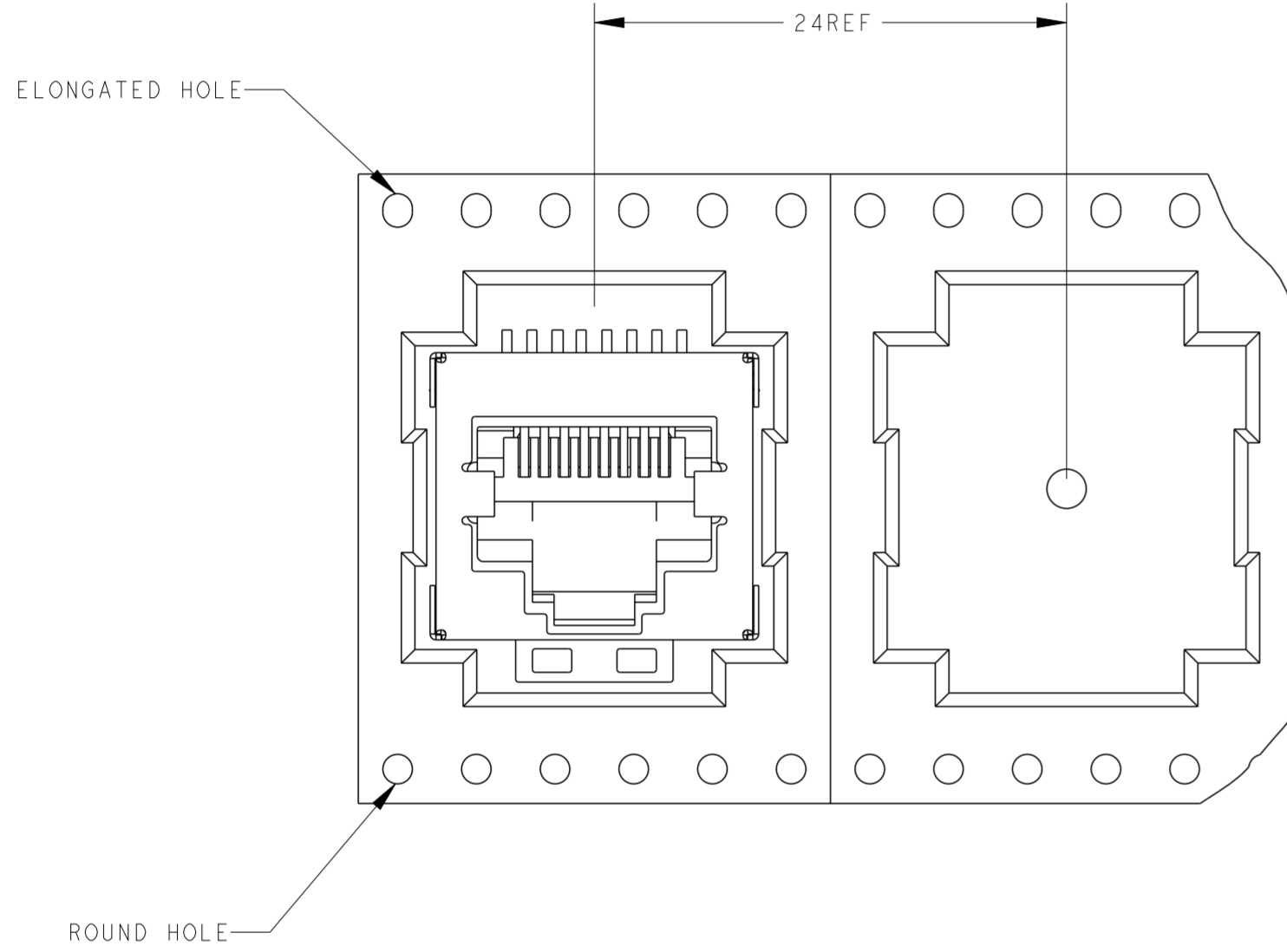

DETAIL A
SCALE 3:1

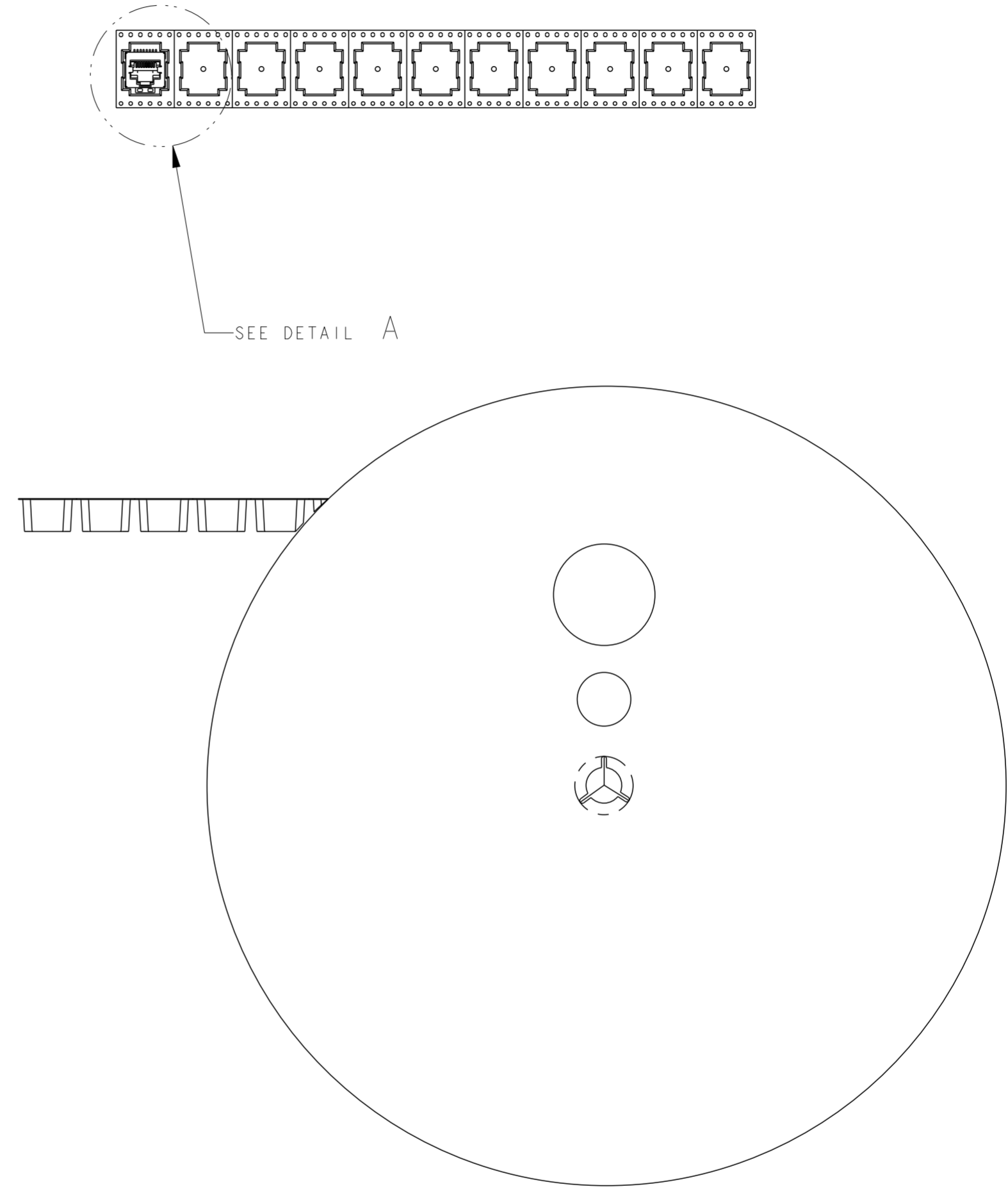

SCALE 1:2

THIS DRAWING IS A CONTROLLED DOCUMENT.		DWN P. WILLEMS 17 JUN 04	TE Connectivity			
DIMENSIONS: mm		CHK P. GROELS 17 JUN 04				
TOLERANCES UNLESS OTHERWISE SPECIFIED: 0 PLC ± 1 PLC ±0.15 2 PLC ±0.05 3 PLC ±0.005 4 PLC ± ANGLES ± FINISH		APVD P. JAEGER	NAME MODULAR JACK SMT , 8 POSITION,			
MATERIAL		PRODUCT SPEC	SIZE	CAGE CODE	DRAWING NO	RESTRICTED TO
-		APPLICATION SPEC	A20779	C-1705549		
		WEIGHT	SCALE 5:1		SHEET 2 OF 2	REV L1
		CUSTOMER DRAWING				