

Features

Regulated Converters

- Highest power density in SIP8 package
- 1.6kVDC/1 minute isolation
- Efficiency up to 88%
- -40°C to +75°C operating temperature range @ full load
- EN60950 and IEC/EN62368-1 certified
- Industry standard pinout



RS6

**6 Watt
SIP8
Single and Dual
Output**



EN60950-1 certified
IEC/EN62368-1 certified
EN55022 compliant

Description

The RS6 series offer very high power density (2.7W/cm³), wide input voltage range and an industrial operating temperature range of -40°C to +75°C without derating. High efficiency, tight regulation, 2kVDC isolation and remote on/off are just some of the characteristics of this advanced SIP8 6W converter which is ideal for high density power supply designs in demanding industrial applications.

Selection Guide

Part Number	Input Voltage Range [VDC]	Output Voltage [VDC]	Output Current [mA]	Efficiency typ. ⁽¹⁾ [%]	max. Capacitive Load ⁽²⁾ [µF]
RS6-053.3S	4.5 - 9	3.3	1300	83	6600
RS6-0505S	4.5 - 9	5	1200	86	3300
RS6-0512S	4.5 - 9	12	500	87	1600
RS6-0515S	4.5 - 9	15	400	86	1400
RS6-0505D	4.5 - 9	±5	±600	84	±2000
RS6-0512D	4.5 - 9	±12	±250	87	±900
RS6-0515D	4.5 - 9	±15	±200	86	±660
RS6-123.3S	9 - 18	3.3	1300	81	6600
RS6-1205S	9 - 18	5	1200	86	3300
RS6-1212S	9 - 18	12	500	87	1600
RS6-1215S	9 - 18	15	400	87	1400
RS6-1205D	9 - 18	±5	±600	85	±2000
RS6-1212D	9 - 18	±12	±250	87	±900
RS6-1215D	9 - 18	±15	±200	87	±660
RS6-243.3S	18 - 36	3.3	1300	81	6600
RS6-2405S	18 - 36	5	1200	87	3300
RS6-2412S	18 - 36	12	500	87	1600
RS6-2415S	18 - 36	15	400	87	1400
RS6-2405D	18 - 36	±5	±600	85	±2000
RS6-2412D	18 - 36	±12	±250	87	±900
RS6-2415D	18 - 36	±15	±200	87	±660
RS6-483.3S	36 - 75	3.3	1300	81	6600
RS6-4805S	36 - 75	5	1200	87	3300
RS6-4812S	36 - 75	12	500	87	1600
RS6-4815S	36 - 75	15	400	88	1400
RS6-4805D	36 - 75	±5	±600	85	±2000
RS6-4812D	36 - 75	±12	±250	87	±900
RS6-4815D	36 - 75	±15	±200	88	±660

Notes:

Note1: Efficiency is tested by nominal input and full load at +25°C ambient

Note2: Max Cap Load is tested by minimum input and constant resistor load

Specifications (measured @ Ta= 25°C, nominal input voltage, full load and after warm up unless otherwise specified)

BASIC CHARACTERISTICS					
Parameter	Condition		Min.	Typ.	Max.
Input Filter	capacitor				
Input Voltage Range	nom. Vin=	5VDC 12VDC 24VDC 48VDC	4.5VDC 9VDC 18VDC 36VDC	5VDC 12VDC 24VDC 48VDC	9VDC 18VDC 36VDC 75VDC
Input Surge Voltage	1 second max.	nom. Vin=			15VDC 25VDC 50VDC 100VDC
Quiescent Current		nom. Vin=			105mA 55mA 28mA 14mA
Output Voltage Trimming	see calculation on next page		Trim up Trim down		+10% -8%
Start-up Time				2ms	
Under Voltage Lockout	nom. Vin= 5V		DC-DC ON DC-DC OFF	4.5VDC 2.7VDC	
	nom. Vin= 12V		DC-DC ON DC-DC OFF	9VDC 7VDC	
	nom. Vin= 24V		DC-DC ON DC-DC OFF	18VDC 15VDC	
	nom. Vin= 48V		DC-DC ON DC-DC OFF	36VDC 30VDC	
ON/OFF CTRL		DC-DC ON DC-DC OFF			Open 5V < Vr < 12VDC
Input Current of CTRL Pin			1.5mA	2.5mA	3.3mA
Standby Current				2mA	
Internal Operating Frequency		0-100% load	200kHz		
Minimum Load				0%	
Output Ripple and Noise ⁽³⁾		20MHz BW		50mVp-p	75mVp-p

Notes:

Note3: Measurements are made with a 1.0µF MLCC across output (low ESR)

Efficiency vs. Load

RS6-1205S

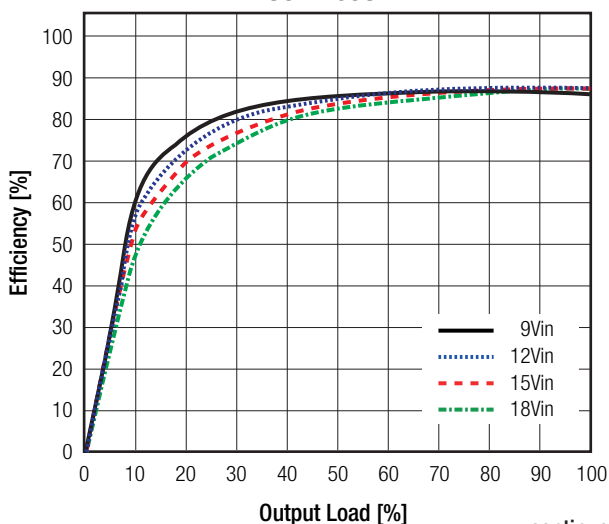

RS6-2405S

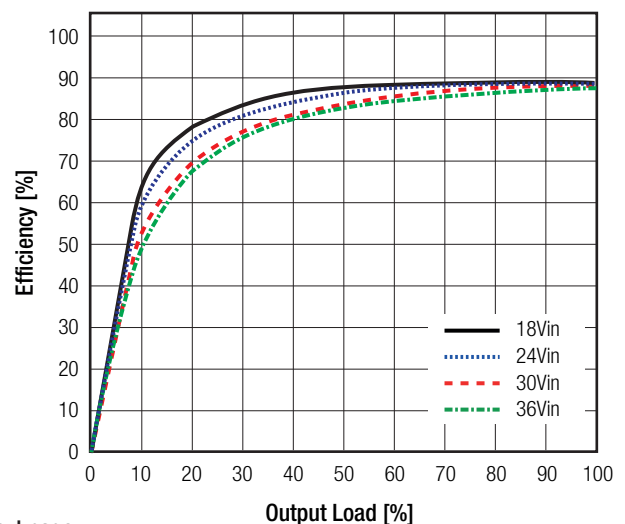

continued on next page

Specifications (measured @ Ta= 25°C, nominal input voltage, full load and after warm up unless otherwise specified)

Output Voltage Trimming

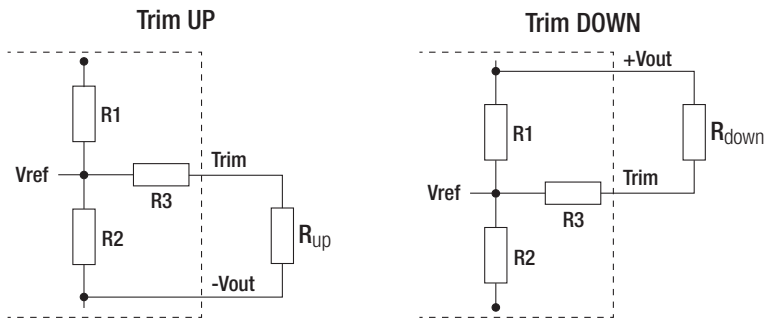

Vout	3.3V	5V	12V	15V
R1	16.74kΩ	10kΩ	38kΩ	50kΩ
R2	10kΩ			
R3	52.3kΩ	39kΩ	68kΩ	68kΩ
Vref	1.24V		2.5V	

Trim Calculation

Vout = nom. Output Voltage

ΔV_{out} = Output Voltage Trim

R_{up} = Trim up resistor

R_{down} = trim down resistor

a = trim up factor

b = trim down factor

$$\Delta V_{out} = V_{out} - V_{out_{trimmed}}$$

$$R_{up} = \left[\frac{a \cdot R2}{R2 - a} \right] - R3 = k\Omega$$

$$R_{down} = \left[\frac{b \cdot R1}{R1 - b} \right] - R3 = k\Omega$$

$$a = \left[\frac{V_{ref}}{(V_{out} + \Delta V_{out}) - V_{ref}} \right] * R1 = k\Omega$$

$$b = \left[\frac{(V_{out} + \Delta V_{out}) - V_{ref}}{V_{ref}} \right] * R2 = k\Omega$$

Practical Example:

Trim Up:

Vout = 5V, ΔV_{out} = 0.5V (10%), Vref = 2.5V

$$a = \left[\frac{2.5V}{(5V + 0.5V) - 2.5V} \right] * 10k\Omega = 8.33k\Omega$$

$$R_{up} = \left[\frac{8.33k\Omega * 10k\Omega}{10k\Omega - 8.33k\Omega} \right] - 39 = 11.0k\Omega$$

RS6-xx03.3S

Trim up	1	2	3	4	5	6	7	8	9	10	%
Vout =	3.33	3.36	3.39	3.43	3.46	3.49	3.53	3.56	3.59	3.63	Volts
R _{up} =	1151.73	360.87	197.07	126.28	86.79	61.60	44.14	31.32	21.15	13.76	kOhms

RS6-xx05S

Trim up	1	2	3	4	5	6	7	8	9	10	%
Vout =	5.05	5.10	5.15	5.20	5.25	5.30	5.35	5.4	5.45	5.50	Volts
R _{up} =	461.00	211.00	127.67	86.00	61.00	44.33	32.43	23.50	16.56	11.00	kOhms

RS6-xx12S

Trim up	1	2	3	4	5	6	7	8	9	10	%
Vout =	12.12	12.24	12.36	12.48	12.60	12.72	12.84	12.96	13.08	13.20	Volts
R _{up} =	723.67	327.83	195.89	129.92	90.33	63.94	45.10	30.96	19.96	11.17	kOhms

RS6-xx15S

Trim up	1	2	3	4	5	6	7	8	9	10	%
Vout =	15.15	15.3	15.45	15.60	15.75	15.90	16.05	16.20	16.35	16.50	Volts
R _{up} =	765.33	348.67	209.78	140.33	98.67	70.89	51.05	36.17	24.59	15.33	kOhms

continued on next page

Specifications (measured @ Ta= 25°C, nominal input voltage, full load and after warm up unless otherwise specified)

Trim down:

Vout = 5V, ΔVout = -0.4V (-8%), Vref= 2.5V

$$b = \left[\frac{[5V + (-0.4V)] - 2.5V}{2.5V} \right] * 10k\Omega = 8.4k\Omega \quad R_{down} = \left[\frac{8.4k\Omega * 10k\Omega}{10k\Omega - 8.4k\Omega} \right] - 39k\Omega = 13.5k\Omega$$

RS6-xx03.3S

Trim down	-1	-2	-3	-4	-5	-6	-7	-8	%
Vout =	3.267	3.234	3.201	3.168	3.135	3.102	3.069	3.036	Volts
R _{down} =	643.60	355.96	233.75	166.13	123.19	93.52	71.78	55.17	kOhms

RS6-xx05S

Trim down	-1	-2	-3	-4	-5	-6	-7	-8	%
Vout =	4.95	4.90	4.85	4.80	4.75	4.70	4.65	4.60	Volts
R _{down} =	451.00	201.00	117.67	76.00	51.00	34.33	22.43	13.50	kOhms

RS6-xx12S

Trim down	-1	-2	-3	-4	-5	-6	-7	-8	%
Vout =	11.88	11.76	11.64	11.52	11.40	11.28	11.16	11.04	Volts
R _{down} =	2902.33	1398.17	896.78	646.08	495.67	395.39	323.76	270.04	kOhms

RS6-xx15S

Trim down	-1	-2	-3	-4	-5	-6	-7	-8	%
Vout =	14.85	14.70	14.55	14.40	14.25	14.10	13.95	13.80	Volts
R _{down} =	4048.67	1965.33	1270.89	923.67	715.33	576.44	477.24	402.83	kOhms

REGULATIONS

Parameter	Condition	Values
Output Accuracy		±1.0% typ.
Line Regulation	low line to high line	±0.2% typ.
Load Regulation	0% to 100% load	1.0% typ.
Cross Regulation	25% to 100% load	±5.0% typ.
Transient Response	25% load step change	500μs typ.

Accuracy vs Load

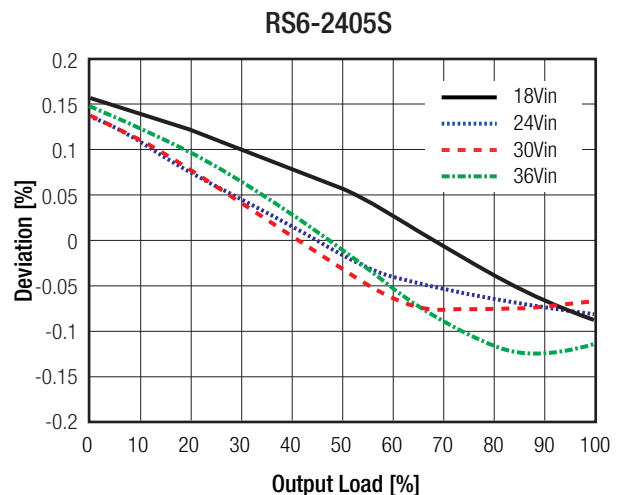
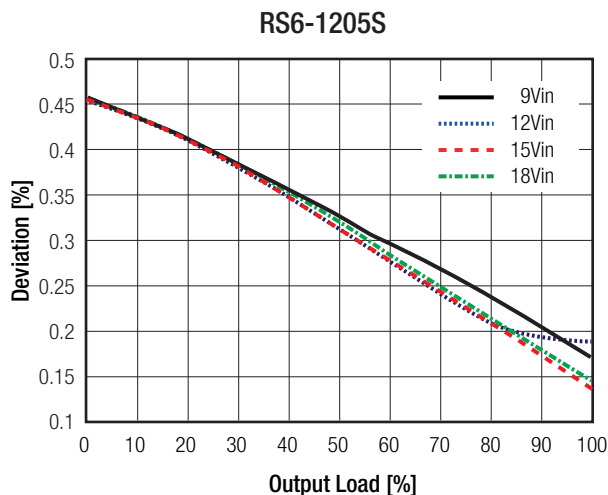

Specifications (measured @ Ta= 25°C, nominal input voltage, full load and after warm up unless otherwise specified)

PROTECTIONS			
Parameter	Condition		Value
Short Circuit Protection (SCP)	below 100mΩ		continuous, automatic recovery
Over Load Protection (OLP)			150% load, continuous, automatic recovery
Isolation Voltage ⁽⁴⁾	I/P to O/P	tested for 1 second rated for 1 minute	2kVDC 1.6kVDC
Isolation Capacitance			110pF max.
Isolation Resistance			1GΩ typ.
Isolation Grade			functional
Notes:			
Note4: For repeat Hi-Pot testing, reduce the time and/or the test voltage			

ENVIRONMENTAL			
Parameter	Condition		Value
Operating Temperature Range ⁽⁶⁾	full load (see graph)		-40°C to +75°C
Maximum Case Temperature			+105°C
Temperature Coefficient			±0.02%/°C
Operating Humidity	non-condensing		5% - 95% RH max.
Vibration			MIL-STD-202G
MTBF	according to MIL-HDBK-217F, G.B.	+25°C	1776 x 10 ³ hours

Derating Graph
 (@ Chamber and natural convection 0.1m/s)

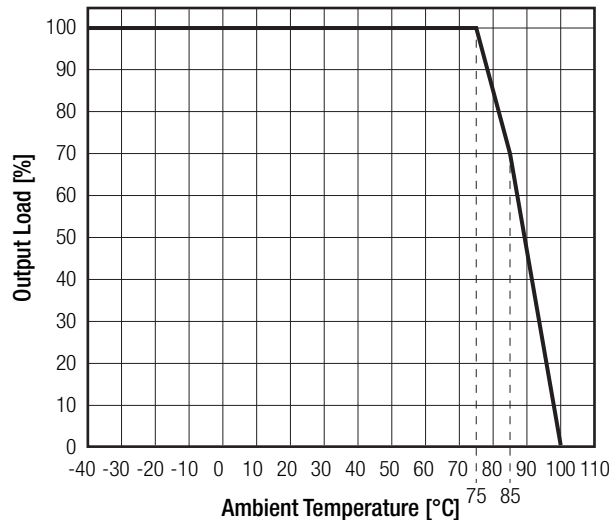

Notes:
 Note5: Derating Graph is referring to RS6-0505S. For more details, please contact our technical support service at TechsupportAT@recom-power.com

SAFETY AND CERTIFICATIONS		
Certificate Type	Report / File Number	Standard
Information Technology Equipment, General Requirements for Safety (LVD)	L0339m26-B1-L	EN60950-1, 2nd Edition AM2 , 2013
Audio/video, information and communication technology equipment - Safety requirements	L0339m27-B1-L	ICE/EN62368-1, 2014
RoHS2		RoHS-2011/65/EU + AM-2015/863
EMC Compliance	Condition	Standard / Criterion
Information technology equipment - Radio disturbance characteristics - Limits and methods of measurement	with external filter	EN55022, Class A
	(see filter suggestions)	EN55022, Class B
Information technology equipment - Immunity characteristics - Limits and methods of measurement		EN55024, 2010

continued on next page

Specifications (measured @ Ta= 25°C, nominal input voltage, full load and after warm up unless otherwise specified)

ESD Electrostatic discharge immunity test	±8kV Air Discharge, ±4kV Contact Discharge	EN61000-4-2, Criteria A
Radiated, radio-frequency, electromagnetic field immunity test	3V/m	EN61000-4-3, Criteria A
Fast Transient and Burst Immunity	±0.5kV	EN61000-4-4, Criteria A
Surge Immunity	±0.5kV	EN61000-4-5, Criteria A
Immunity to conducted disturbances, induced by radio-frequency fields	3Vr.m.s	EN61000-4-6, Criteria A
Power Magnetic Field Immunity	50Hz, 1A/m	EN61000-4-8, Criteria A

EMC Filtering - Suggestions for EN55022 Class A

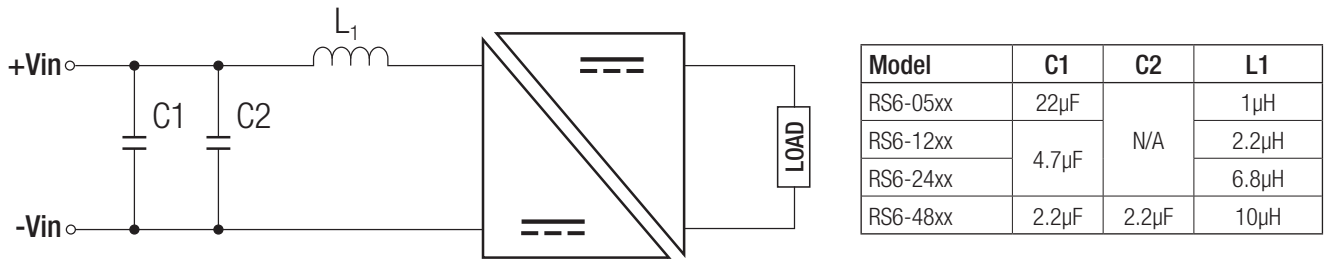

EMC Filtering - Suggestions for EN55022 Class B

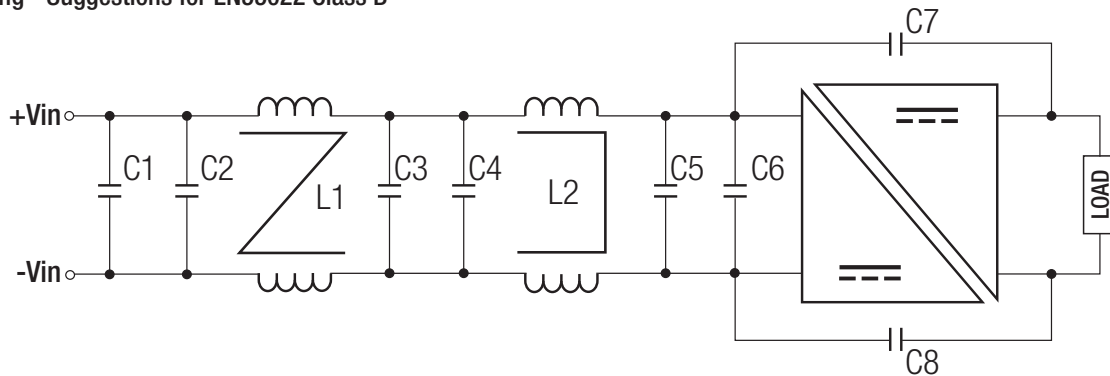

Model	C1	C2	L1	C3	C4	L2	C5	C6	C7	C8
RS6-05xx	22µF	N/A	1µH CMC	10µF	N/A	200µH DMC	10µF	N/A	47pF	100pF
RS6-12xx	10µF		6.8µH CMC							
RS6-24xx	4.7µF		10µH CMC	4.7µF						
RS6-48xx	2.2µF	2.2µF	22µH CMC	2.2µF	2.2µF	600µH DMC	1µF	N/A	47pF	680pF

Surge Protection Circuit according to EN61000-4-5, Criteria A

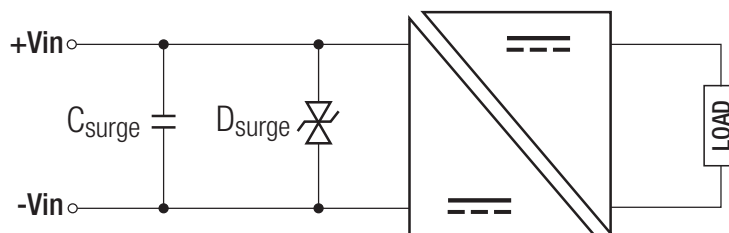

nom. VIN	Csurge	Dsurge	max. Surge Voltage
5VDC	100V, 220µF E/Cap	TVS (P4SMAJ15CA)	±1kVDC
12VDC		N/A	
24VDC			
48VDC			

Specifications (measured @ Ta= 25°C, nominal input voltage, full load and after warm up unless otherwise specified)

DIMENSION and PHYSICAL CHARACTERISTICS

Parameter	Type	Value
Material	case potting	non conductive plastic (UL94V-0) epoxy (UL94V-0)
Dimension (LxWxH)		21.8 x 9.2 x 11.1mm
Weight		4.0g

Dimension Drawing (mm)

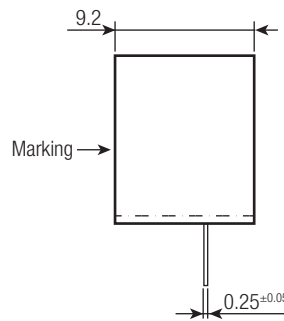
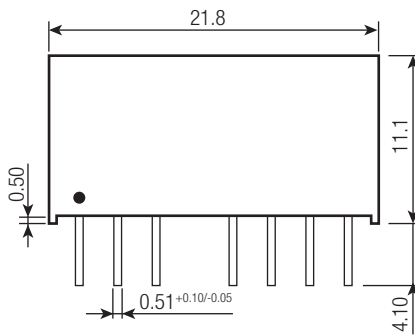
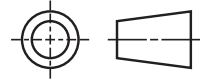

Pin Connections

Pin #	Single	Dual
1	-Vin	-Vin
2	+Vin	+Vin
3	CTRL ⁽⁶⁾	CTRL ⁽⁶⁾
5	Trim	NC
6	+Vout	+Vout
7	-Vout	Com
8	NC	-Vout

NC= no connection
Tolerance: xx.x= ±0.5mm
 xx.xx= ±0.25mm
Pin dimension: ±0.1mm
Pin pitch: ±0.25mm

Recommended Footprint Details

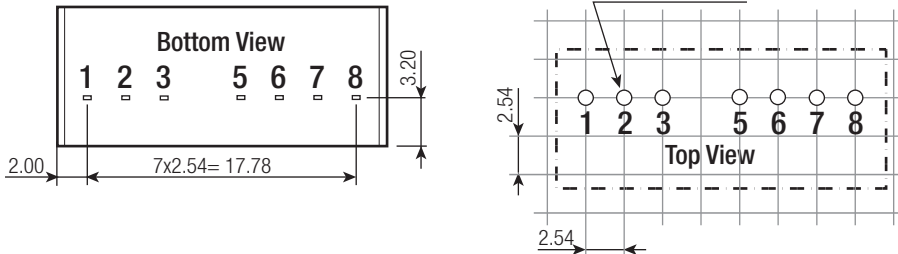

Notes:

Note6: This pin provides an Off function which puts the converter into a low power mode. When the pin is 'high' the converter is OFF and when the pin is high 'Z' the converter is ON. There is no allowed low state for this pin

PACKAGING INFORMATION

Parameter	Type	Value
Packaging Dimension (LxWxH)	tube	520.0 x 18.2 x 11.2mm
Packaging Quantity		22pcs
Storage Temperature Range		-55°C to +125°C
Storage Humidity	non-condensing	95% RH max.

The product information and specifications may be subject to changes even without prior written notice. The product has been designed for various applications; its suitability lies in the responsibility of each customer. The products are not authorized for use in safety-critical applications without RECOM's explicit written consent. A safety-critical application is an application where a failure may reasonably be expected to endanger or cause loss of life, inflict bodily harm or damage property. The applicant shall indemnify and hold harmless RECOM, its affiliated companies and its representatives against any damage claims in connection with the unauthorized use of RECOM products in such safety-critical applications.